

## Foundation Check In - 10.04 Volume and surface area calculations

1. Calculate the surface area of a cuboid with dimensions  $2\text{ m} \times 3\text{ m} \times 5.5\text{ m}$ .
2. Calculate the volume of the shape below made from two cuboids.

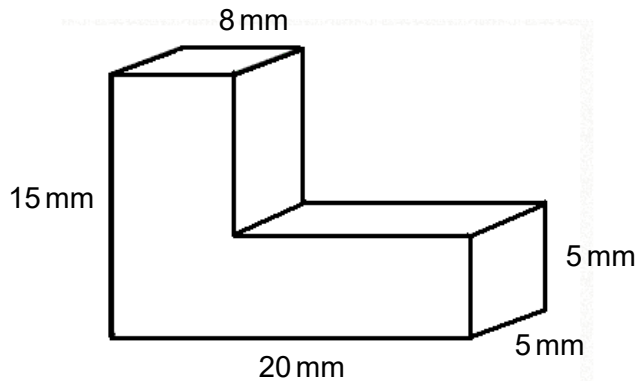

3. Calculate the volume of a cylinder with diameter  $6\text{ cm}$  and height  $4\text{ cm}$ .
4. Calculate the total surface area of the pyramid below, where each triangular face of this square-based pyramid has a perpendicular height of  $12.3\text{ cm}$  and base  $7.5\text{ cm}$ .

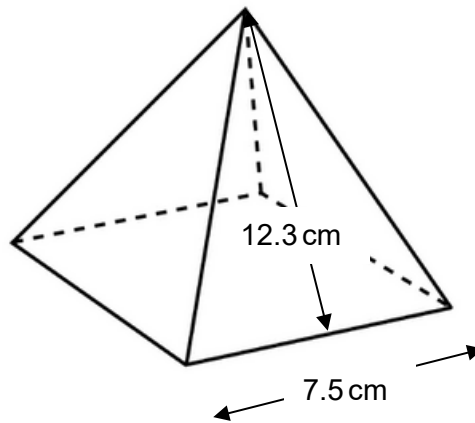

5. Use the formula  $V = \frac{1}{3}\pi r^2 h$  to calculate the volume ( $V$ ) of a cone with radius ( $r$ ) of  $3\text{ m}$  and height ( $h$ ) of  $1.5\text{ m}$ . Give your answer to 1 decimal place.
6. A sphere has a volume ( $V$ ) of  $2304\pi\text{ cm}^3$ . What is its radius ( $r$ )?  
Use the formula  $V = \frac{4}{3}\pi r^3$ .



7. The curved surface area ( $S$ ) of a cone is given by the formula  $S = \pi \times \text{radius} \times \text{slant height}$ .  
Emer calculates the curved surface area of this cone as  $\pi \times 10 \times 12 = 376.99 \text{ cm}^2$  (to 2 dp). Explain two mistakes she has made.

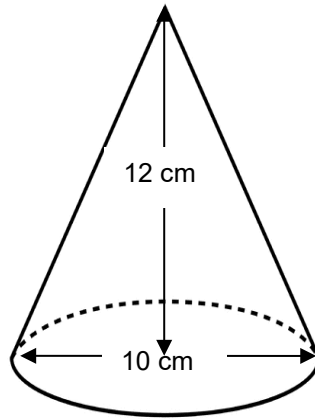

8. Jo says, "If I cut a solid cube in half, the surface area of each piece will be half the surface area of the original cube."  
Is Jo right? Explain your answer.
9. The distance from the surface of the Earth to its centre is about 6400 km.  
Roughly 360 million square kilometres of the Earth's surface is covered in water.  
Estimate the proportion of the Earth's surface that is covered in water.  
Use the formula  $A = 4\pi r^2$ .
10. A cylindrical steel rod with radius 1.2 cm and length 18 cm is cut from an 18 cm long steel cuboid with square ends. Find the volume of metal wasted.

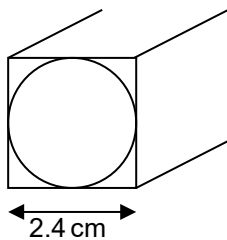

## Extension

A cuboid has a square cross-section and is 12 cm long. The numeric value of the total surface area of the cuboid is the same as its volume. Find the dimensions of the cuboid.



# GCSE (9–1) MATHEMATICS

## Answers

1.  $67 \text{ m}^2$
2.  $900 \text{ mm}^3$
3.  $113 \text{ cm}^3$
4.  $240.75 \text{ cm}^2$
5.  $14.1 \text{ m}^3$
6. 12 cm
7. Used diameter instead of radius.  
Used perpendicular height instead of slant height (which is 13 cm found using Pythagoras' theorem).
8. No with stated reason i.e. two extra end surfaces created oe. Accept calculation for a specific cube or algebraic generalisation.
9. ~70%
10.  $22.2 \text{ cm}^3$

## Extension

$$4.8 \times 4.8 \times 12 \text{ cm}$$

We'd like to know your view on the resources we produce. By clicking on '[Like](#)' or '[Dislike](#)' you can help us to ensure that our resources work for you. When the email template pops up please add additional comments if you wish and then just click 'Send'. Thank you.

If you do not currently offer this OCR qualification but would like to do so, please complete the Expression of Interest Form which can be found here: [www.ocr.org.uk/expression-of-interest](http://www.ocr.org.uk/expression-of-interest)

### OCR Resources: *the small print*

OCR's **resources** are provided to support the teaching of OCR specifications, but in no way constitute an endorsed teaching method that is required by the Board, and the decision to use them lies with the individual teacher. Whilst every effort is made to ensure the accuracy of the content, OCR cannot be held responsible for any errors or omissions within these resources.

© OCR 2016 - This resource may be freely copied and distributed, as long as the OCR logo and this message remain intact and OCR is acknowledged as the originator of this work.

OCR acknowledges the use of the following content: n/a

Please get in touch if you want to discuss the accessibility of resources we offer to support delivery of our qualifications: [resources.feedback@ocr.org.uk](mailto:resources.feedback@ocr.org.uk)



Assessment Objective	Qu.	Topic	R	A	G
AO1	1	Calculate the surface area of a cuboid			
AO1	2	Calculate the volume of a simple composite solid			
AO1	3	Calculate the volume of a cylinder			
AO1	4	Calculate the surface area of a pyramid			
AO1	5	Calculate the volume of a cone given the formula			
AO2	6	Use the formula for volume of a sphere to find a radius			
AO2	7	Identify the dimensions to be used in the formula for surface area of a cone			
AO2	8	Use geometric properties to justify an argument			
AO3	9	Solve a problem involving surface area in context			
AO3	10	Solve a problem involving volume in context			

Assessment Objective	Qu.	Topic	R	A	G
AO1	1	Calculate the surface area of a cuboid			
AO1	2	Calculate the volume of a simple composite solid			
AO1	3	Calculate the volume of a cylinder			
AO1	4	Calculate the surface area of a pyramid			
AO1	5	Calculate the volume of a cone given the formula			
AO2	6	Use the formula for volume of a sphere to find a radius			
AO2	7	Identify the dimensions to be used in the formula for surface area of a cone			
AO2	8	Use geometric properties to justify an argument			
AO3	9	Solve a problem involving surface area in context			
AO3	10	Solve a problem involving volume in context			

Assessment Objective	Qu.	Topic	R	A	G
AO1	1	Calculate the surface area of a cuboid			
AO1	2	Calculate the volume of a simple composite solid			
AO1	3	Calculate the volume of a cylinder			
AO1	4	Calculate the surface area of a pyramid			
AO1	5	Calculate the volume of a cone given the formula			
AO2	6	Use the formula for volume of a sphere to find a radius			
AO2	7	Identify the dimensions to be used in the formula for surface area of a cone			
AO2	8	Use geometric properties to justify an argument			
AO3	9	Solve a problem involving surface area in context			
AO3	10	Solve a problem involving volume in context			

Assessment Objective	Qu.	Topic	R	A	G
AO1	1	Calculate the surface area of a cuboid			
AO1	2	Calculate the volume of a simple composite solid			
AO1	3	Calculate the volume of a cylinder			
AO1	4	Calculate the surface area of a pyramid			
AO1	5	Calculate the volume of a cone given the formula			
AO2	6	Use the formula for volume of a sphere to find a radius			
AO2	7	Identify the dimensions to be used in the formula for surface area of a cone			
AO2	8	Use geometric properties to justify an argument			
AO3	9	Solve a problem involving surface area in context			
AO3	10	Solve a problem involving volume in context			

